

## Features:

- Perkins engine
  - Electronic governor
  - Engine safety protection
  - Lube-oil drain manual pump
  - 50°C radiator optional
- Lead acid battery system
  - Battery charger
  - Battery isolator
- Leroy Somer alternator
  - Class H insulation
  - Excitation system: Brushless
  - A.V.R model: D510C
- Control module DSE7420
- Industrial exhaust silencer with stainless steel
  - Flexible bellow
- Heavy duty mild steel construction base plate
  - AVM (Anti-vibration mounts) between engine/alternator and the base plate.
  - Integral base fuel tank with fuel level gauge



## Output Ratings

Generator Set Model	Prime Power		Standby Power	
	kVA	kW	kVA	kW
EP2000	2000	1600	2200	1760

Ratings at 0.8 power factor

## Dimensions and Weights

Model	L × W × H-mm	Dry Weight-kg
EP2000	12192 x 2438 x 3150	24090

### Notes:

\***Prime Power** Continuous duty operation, under variable load 24/24h-10% over load permissible 1 hour/12 hours;

\*\***Standby Power** Standby duty, operation under variable load, without over load;

**Standard Reference Conditions** Note: Standard reference conditions 25°C (77°F) Air Inlet Temp, 100m(328 ft) A.S.L. 30% relative humidity.

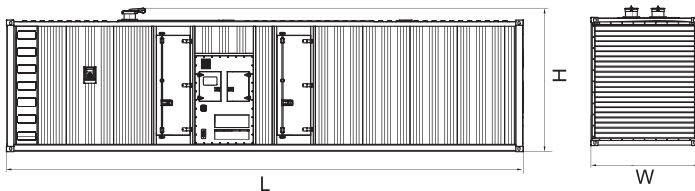

## Ratings and Performance Data

Engine Brand	Perkins
Engine Model	4016-61TRG2
Alternator Brand	Leroy Somer
Alternator Model	LSA52.3S6
Control System	PLC-7420 (DSE)
Circuit Breaker Type	N/A
Frequency / Phase	50Hz/3Phase
Engine Speed ( RPM )	1500
Fuel Tank Capacity ( L )	N/A
Fuel Consumption ( L/h ) (100%load)	421
Noise Level@7m ( dBA )	N/A
Oil Consumption ( L/h )	0.52
Voltage ( V )	380/400/415/440
Silencer Noise Reduction ( dBA )	10-20

**Engine Model: 4016-61TRG2**

### Engine Technical Data

Engine Model	4016-61TRG2
Engine Brand	Perkins
Number of Cylinders	16
Cylinders Arrangement	Vee
Bore/Stroke ( mm )	160/190
Speed ( RPM )	1500
Displacement ( L )	61.123
Compression Ratio	13:1
Air Intake system	Turbocharge Air to water charge cooled
Cooling Method	Air to Water cooled
Coolant Capacity ( L )	210
Prime Gross Power ( kWm )	1774
Standby Gross Power ( kWm )	1985
Governing Type	Electronic
Back Pressure ( mmhg )	4kPa
Battery ( V )	24V

### Fuel System

Fuel Tank	N/A			
Fuel Tank Capacity ( L )	N/A			
Fuel tank type	Double-layer			
Recommended Fuel Type	0# or ASTM2			
Injection System	Direct injection			
<b>Fuel Consumption:</b>				
EP2000	100% Load	75% Load	50% Load	25% Load
L/h	421	337	216	116

(Based on diesel fuel with a specific gravity of 0.85 and conforming to BS2869, Class A2)

### Lubrication System

Lube oil label	
Normal condition Oil Temp. ( °C )	95
Maximum Sump Capacity	213

### Exhaust and silencer System

Exhaust Air Flow ( m <sup>3</sup> /min )	490
Exhaust Air Temp. ( °C )	457
Maximum Allowable Back Pressure ( kpa )	4
NOx ( mg/Nm <sup>3</sup> )	
Silencer Quantity	1/2
Silencer Type	Industrial silencer

### Cooling System

Radiator	50
Coolant Change Time ( Year/h )	2/10000
Engine Coolant Flow	23
Coolant Output Temp. ( °C )	98

Designed to operate in ambient conditions up to 50°C (122°F).

### Air Intake system

Air Filter Type	Dry type
Combustion Air Flow ( m <sup>3</sup> /min ) Prime	158
Intake System	Turbocharge Air to water charge cooled
Intake Air Temp. ( °C )	25

### Conditions

Altitude ( m )	1000
Ambient Temp. ( °C )	-5°C-40°C
Relative Humidity	< 80%

Alternator Model: LSA52.3S6

### Alternator Physical Data

AVR Model	D510C
Alternator Brand	Leroy Somer
Alternator Model	LSA52.3S6 6 wires
Excitation System	Brushless
Housing Protection	IP23
Power Factor	0.8
Rated Stator Temp. rise ( °C )	125
Rotor Insulation Class	H
Voltage Regulation	±0.5%
Winding Pitch	2/3
Wiring Connection	Series Star

### Performance Data

Time constants/400V ( Ms )	
T'd	264
T''d	23
T'do	2760
Ta	28
Short-circuit current (3 IN / 10 s)	300 % (3 IN) : 10s
SHORT CIRCUIT RATIO	1/Xd
Reactances ( Per Unit )	
Xd	380
X'd	30.9
X''d	16.4

### Alternator Operating Data

Overspeed ( rpm )	2250
THD No Load	<4%
TIF	< 50
THF	< 2%
Air Flow ( m³/s ) -Alternator 50Hz/60Hz	2.5/2.8
Altitude-Alternator ( m )	1000

### Voltage Technical Data

Voltage	Prime		Standby	
	kVA	kW	kVA	kW
400V@50Hz	2000	1600	2200	1760
440V@50Hz	1818	1454	2000	1600
416V@60Hz	2080	1664	2288	1830
440V@60Hz	2200	1760	2420	1936
480V@60Hz	2400	1920	2640	2112

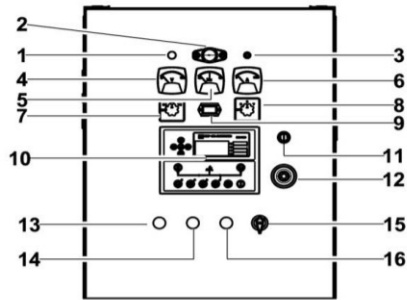

**Control cabinet**

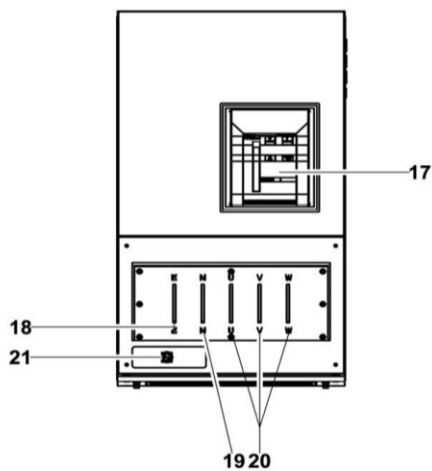

**Field wiring cabinet**

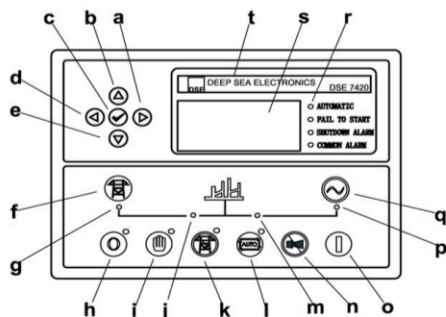

**Control module**

Ref.	Description
1	Charge indicator
2	Control cabinet lamp
3	Control cabinet lamp switch
4	Voltage meter
5	Frequency meter
6	Current meter
7	Changerover switch-Voltage
8	Changerover switch-Current
9	Time counter
10	Control module
11	Key switch
12	Emergency stop switch
13	Fuel leak indicator
14	Running button with indicator
15	Oil drain switch
16	Stop button with indicator
17	Main circuit breaker
18	Ground wire terminal
19	Neutral wire terminal
20	Live wire terminals
21	Mains input/Remote control/ ATS communication connector

a	Button (next page)
b	Button (increase value / previous item)
c	Button (accept)
d	Button (previous page)
e	Button (decrease value / next item)
f	Button (transfer the load to the mains supply, when in Manual mode only)
g	Mains supply available LED
h	Stop / Reset button
i	Manual button (Manual control mode)
j	Mains supply on load LED
k	Test button (Test mode)
l	Auto button (Auto mode)
m	Genset on load LED
n	Mute/Lamp test button
o	Start button (Manual)
p	Genset available LED
q	Button (transfer the load to the genset, when in Manual mode only)
r	Alarm LED (4 alarm items)
s	LCD display
t	Control module name